

Condensate removal pumps

Air conditioning - Refrigeration - Heating





Factory (Madagascar)



Headquarter (France)



Factory (China)

FEW WORDS ABOUT SICCOM

SICCOM S.A.S was founded in 1979 and specialises in condensate removal pumps, level and proximity sensors, bimetal heat protection, and interference suppressors for car industry.

SICCOM's expertise means customers can benefit from a range of high added-value products that meet installers' requirements.

SICCOM technology is designed and implemented by its own engineering department, made up of a number of highly qualified engineers and technicians.

SICCOM constantly strives to innovate and now enjoys worldwide success in more than 50 countries

As it has grown, it has opened factories in Madagascar and China, and subsidiaries in Milan, Barcelona and New Delhi alongside its head office in the Paris area.

This international presence means it is able to supply customers regardless of any particular geopolitical situation.

Eco-design

Fully aware that the virtuous eco-design cycle is beneficial to everyone, SICCOM has chosen to fully integrate this approach into its various production phases.

The mini FLOWATCH® 2, the brand's star product, has been the first product illustrating this approach. The environmental impact has been reduced from 5 to 20%, and the life has been multiplied by 2. More recently, the mini FLOWATCH® 0 reached 65.6% of environmental impact reduction for its use phase!

Our approach:

«Significant environmental improvements,
better service for our customers.»

Certifications





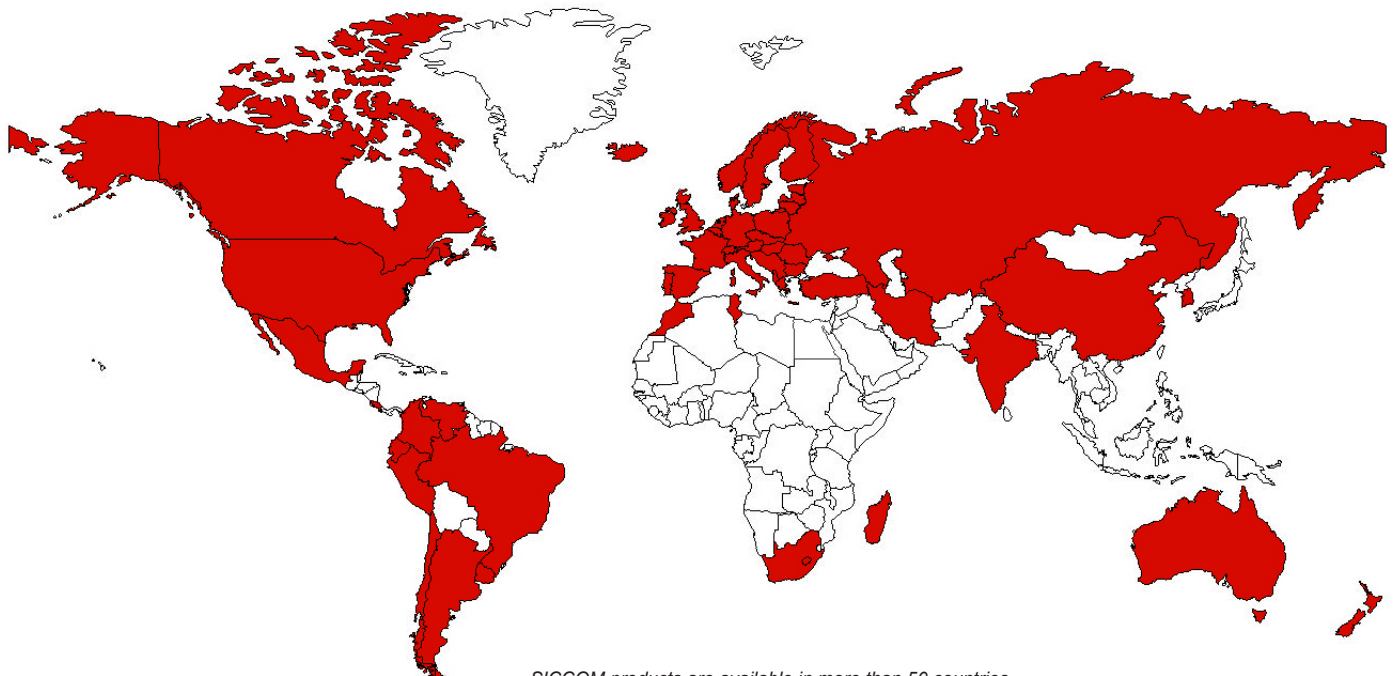





























All our sites have received ISO 9001 version 2015 certification.

Quality procedures encompass all of the company's services, ensuring optimal quality levels.



SICCOM products are available in more than 50 countries.

CONTENTS

	 Air conditioning	 Refrigeration	 Heating	Flowrate max	Discharge head max	Page		
PREMIUM RANGE	mini FLOWATCH® 2				15 l/h	10 m	4	
	mini FLOWATCH® 2 COMFORT NEW				15 l/h	10 m	5	
	FLOWATCH® DESIGN				15 l/h	10 m	6	
	mini FLOWATCH® 3 WiFi				15 l/h	10 m	7	
	mini FLOWATCH® 3 WiFi DESIGN				15 l/h	10 m	8	
	FLOWATCH® VISION				15 l/h	10 m	9	
	SUNNY FLOWATCH® CLIM				15 l/h	10 m	10	
	FLOWATCH® TANK				788 l/h	5.5 m	11	
	Centrifugal pump CP08				60 l/h	110 cm	12	
	ECO RANGE	mini FLOWATCH® 0				10 l/h	10 m	13
ECO FLOWATCH®					13.2 l/h	10 m	14	
ECO FLOWATCH® DESIGN					13.2 l/h	10 m	15	
ECO LINE					13.2 l/h	10 m	16	
MAXI ECO FLOWATCH®					40 l/h	10 m	17	
mini FLOWATCH® 1 EVO NEW					13.2 l/h	10 m	18	
FLOWITA EVO NEW					13.2 l/h	10 m	19	
ECOTANK+ 1.2 / ECOTANK+ 2.5					300 l/h (50Hz) 400 l/h (60Hz)	4.6 m (50Hz) 6 m (60Hz)	20	
DUO RANGE		mini FLOWATCH® 2 DUO				19 l/h	10 m	21
		FLOWATCH® VISION DUO				19 l/h	10 m	22
	SUNNY FLOWATCH® DUO				19 l/h	10 m	23	
	Pump accessories						24	
Level and proximity sensors						25		

PREMIUM RANGE

Reliable, longlasting, silent and efficient, these pumps perfectly meet instalers and final users' expectations.

They are all equipped with an **integrated alarm** (except CP08) are among the **quietest on the market**.

ECO RANGE

A range of pumps **simple, reliable and easy-to-install**.

Meet SICCOM expertise in **entry-level pumps** at prices even more attractive.

DUO RANGE

SICCOM proposes a range especially developed for removing condensates from **gas condensing boilers**.

These pumps are alternatives, more compact and silent, to tank pumps such as FLOWATCH® TANK and ECOTANK+

mini FLOWATCH® 2

SICCOM

Mini solenoid pump reliable and silent for the condensate removal of air conditioners up to 10kW / 36000BTU.

Ref: DE05LC4400

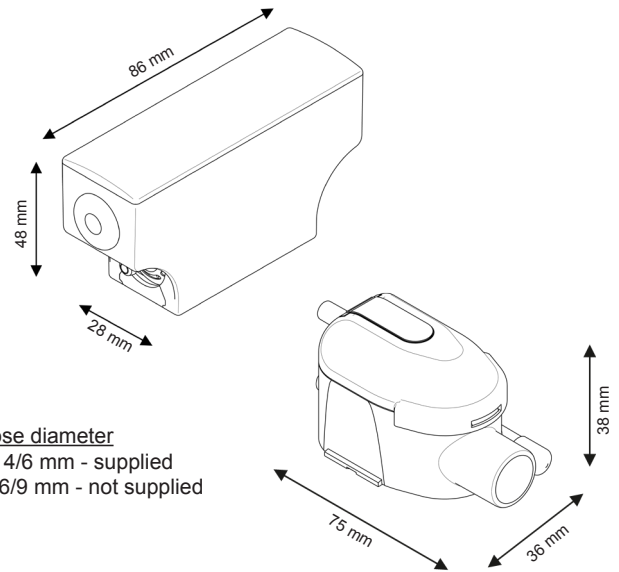

Hose diameter
Suction : 4/6 mm - supplied
Discharge : 6/9 mm - not supplied

SPECIFICATIONS

Flowrate max	15 l/h
Suction head max	2 m
Discharge head	10 m
Electrical power	19W
Voltage	220-240V 50/60Hz
Alarm	NO-NC
Noise level*	
Protection rating	IP64
Thermal protection	Yes
Operating cycle**	100%
Power / alarm cable	1.6 m
Dimensions	86 x 28 x 48 mm / 75 x 38 x 36 mm

* Notation from 1 wave (≤ 20 dBA) to 6 waves (> 45 dBA)
** The pump is able to run 100% of the time if necessary.

FLOWRATE

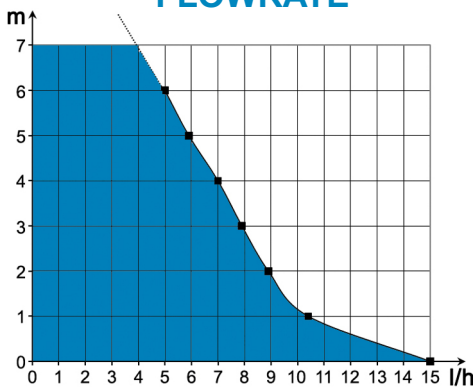

Recommended accessory

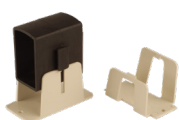

Kit Silence

Reduces the noise level and makes the installation easier.

Ref: GC1KFX2010

BENEFITS



Very silent

Very silent pump (20.2 dBA), suitable for an installation in any room.



IP64 protection

Protected against water splashes and dust.



Quick connectors

Make installation and maintenance easier.



Clear reservoir

Facilitates maintenance thanks to a quick visualization of the reservoir state.



Brass outlet

More solid and reliable than plastic outlet.



Accessories included

All accessories required for installation are included in the box.

CONTENTS



Pump - Reservoir with air-vent tube - Power / alarm cable - Reservoir stand - Double-side adhesive - Inlet tube - Suction tube 1.8m - 1 clamp

mini FLOWATCH® 2 COMFORT

SICCOM

The best mini pump on the market in a quieter and easy-to-install version, for the condensate removal of air conditioners up to 10kW / 36000BTU.

Ref: DE05LCD750



NEW

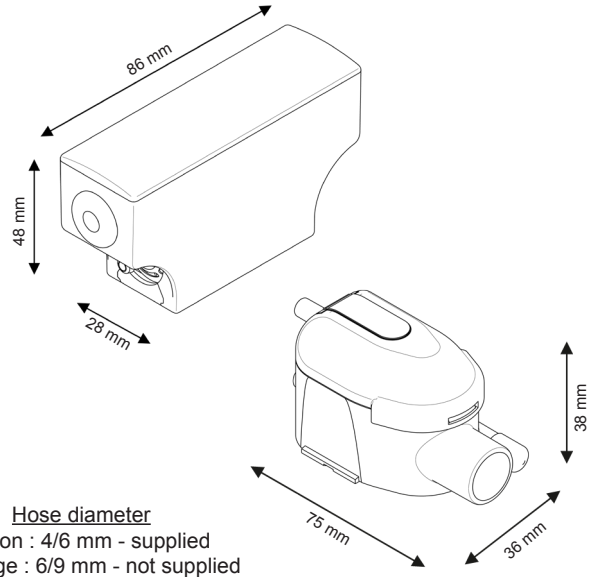

SPECIFICATIONS

Flowrate max	15 l/h
Suction head max	2 m
Discharge head	10 m
Electrical power	19W
Voltage	220-240V 50/60Hz
Alarm	NO-NC
Noise level*	
Protection rating	IP64
Thermal protection	Yes
Operating cycle**	100%
Power / alarm cable	1.6 m
Dimensions	86 x 28 x 48 mm / 75 x 38 x 36 mm

* Notation from 1 wave (≤ 20 dBA) to 6 waves (> 45 dBA)

** The pump is able to run 100% of the time if necessary.

BENEFITS



New casing Comfort

The new Comfort casing is composed of a custom-made patented foam.

It dampens pump vibrations and reduces the perceived noise level.

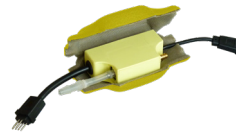

Reliability proven

The mini FLOWATCH® 2, included, is a reliable and durable pump sold in more than 35 countries.



Very silent

Thanks to its casing, the pump is extremely quiet and suitable for installation in any room.



Pump stand included

Make pump installation and maintenance easier.



Stop siphoning included

Allows to avoid all risk of negative discharge and to secure the pump functioning over time.



Quick connectors

Make installation and maintenance easier.



IP64 protection

Protected against water splashes and dust.

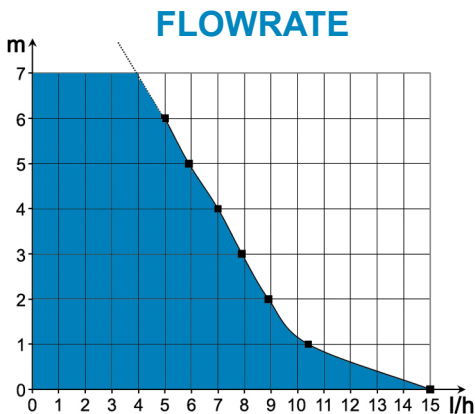

CONTENTS

Pump - Reservoir with air-vent tube - Power / alarm cable - Comfort casing - Pump stand - Reservoir stand - Stop Siphoning - Double-sided adhesive - Inlet tube - Suction tube 1.8m - 4 clamps

FLOWATCH® DESIGN

SICCOM

Complete kit, in-duct pump, for the condensate removal of air conditioners up to 10kW / 36000BTU.

Ref: DE05LC9460

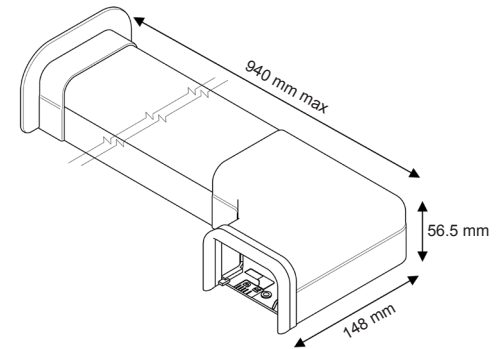
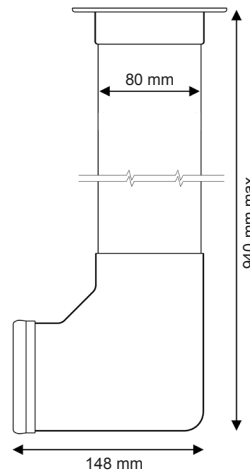

Hose diameter
Suction : 4/6 mm - supplied
Discharge : 6/9 mm - not supplied

SPECIFICATIONS

Flowrate max	15 l/h
Discharge head	10 m
Electrical power	19W
Voltage	220-240V 50/60Hz
Alarm	NO-NC
Noise level*	
Protection rating	IP64
Thermal protection	Yes
Operating cycle**	100%
Power / alarm cable	1.6 m
Trunking dimensions	80 x 55 x 800 mm

* Notation from 1 wave (≤ 20 dBA) to 6 waves (> 45 dBA)

** The pump is able to run 100% of the time if necessary.

FLOWRATE

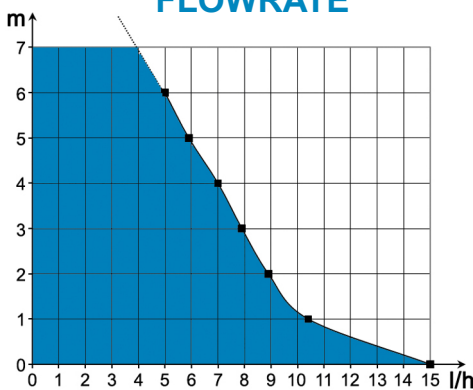

Recommended accessory



Connection extension kit

Allows the pump to be moved into a false ceiling, thus reducing the noise level.

Ref: GC1KCTC710

BENEFITS



mini FLOWATCH® 2 included

It assures a high reliability and an easy maintenance.



Very silent

Very silent pump (20.2 dBA), suitable for an installation in any room.



IP64 protection

Protected against water splashes and dust.



Stop siphoning included

Allows to avoid all risk of negative discharge and to secure the pump functioning over time.



Nice design

Thanks to its shape and its finishing accessories (included), FLOWATCH® DESIGN offers great aesthetics qualities.



Kit pre-assembled

Pump is already installed in its duct. Installation is easy and quick.

CONTENTS

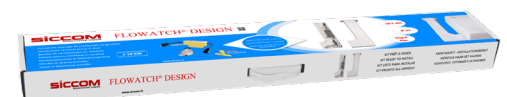

Duct with elbow- Finishing gasket - Finishing ceiling plate - Pump in absorber bracket - Reservoir with air-vent tube - Power / alarm cable - Reservoir stand - Inlet tube - Suction tube 0.25m - Screws and rawlplugs

mini FLOWWATCH® 3 WiFi



As a real product of predictive maintenance, the mini FLOWWATCH® 3 WiFi allows to remotely supervise a fleet of pumps and to anticipate a maintenance on a pump or an air conditioner. For air conditioners up to 10kW / 36000BTU.

Ref: DE05WFCC760



The first
condensate pump
WiFi connected



Hose diameter
Suction : 4/6 mm - supplied
Discharge : 6/9 mm - not supplied

Monitor your **pump fleet** in the blink of an eye!

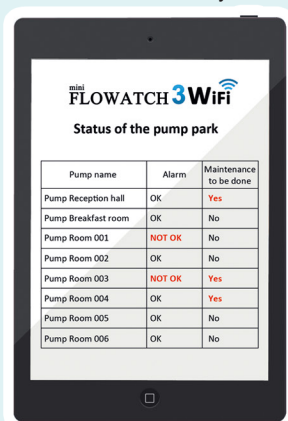

View all pump datas

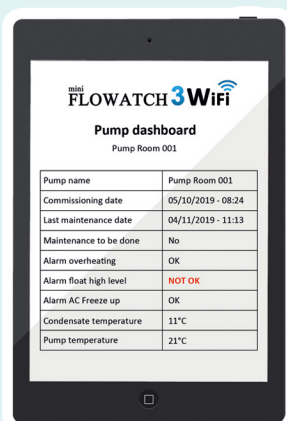

The pump sends you an email when an alarm triggers!

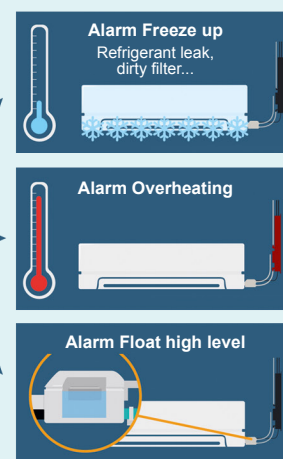

SPECIFICATIONS

Flowrate max	15 l/h
Suction head max	2 m
Discharge head	10 m
Electrical power	21W
Voltage	220-240V 50/60Hz
Alarm	NC
Noise level*	
Protection rating	IPX4
Thermal protection	Yes
Operating cycle**	100%
Power / alarm cable	1.6 m
Dimensions	272 x 35 x 43 mm / 75 x 38 x 36 mm

* Notation from 1 wave (≤ 20 dBA) to 6 waves (> 45 dBA)

** The pump is able to run 100% of the time if necessary.

BENEFITS



Web interface

The interface is accessible from a computer, smartphone, or tablet and requires no software or application installation.



Email sending in case of alarm

Be notified immediately in the event of a malfunction (3 alarm cases).



Real-time supervision

Access a wealth of information about your pump fleet in just a few clicks.



Pump interconnection

Create a network of pumps, and allow them to communicate with each other for more productive management of your pump fleet.



Extremely silent

The quietest pump of our range (18.6 dBA), for an installation in any room.



Stop siphoning included

Allows to avoid all risk of negative discharge and to secure the pump functioning over time.

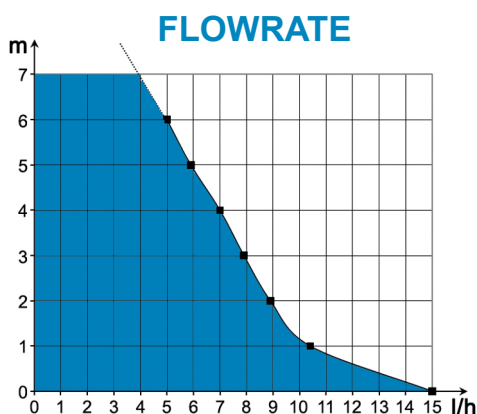

CONTENTS

Pump - Reservoir with air-vent tube - Reservoir stand - Double-side adhesives - Inlet tube - Suction tube 1.8m - Clamps

mini FLOWWATCH® 3 WiFi DESIGN

SICCOM

WiFi connected pump in duct version, ready to install, for the condensate removal from air conditioners up to 10kW / 36000BTU.

Ref: DE05WFCD760



All the benefits of the
mini FLOWWATCH® 3 WiFi
in a trunking version



BENEFITS



Web interface

The interface is accessible from a computer, smartphone, or tablet and requires no software or application installation.



Email sending in case of alarm

Be notified immediately in the event of a malfunction (3 alarm cases).

SPECIFICATIONS

Flowrate max	15 l/h
Discharge head	10 m
Electrical power	21W
Voltage	220-240V 50/60Hz
Alarm	NO-NC
Noise level*	
Protection rating	IPX4
Thermal protection	Yes
Operating cycle**	100%
Power / alarm cable	1.6 m
Trunking dimensions	80 x 55 x 800 mm

* Notation from 1 wave (≤ 20 dBA) to 6 waves (> 45 dBA)

** The pump is able to run 100% of the time if necessary.



Real time supervision

Access a wealth of information about your pump fleet in just a few clicks.



Pump interconnection

Create a network of pumps, and allow them to communicate with each other for more productive management of your pump fleet.



Extremely silent

The quietest pump of our range (18.6 dBA), for an installation in any room.



Stop siphoning included

Allows to avoid all risk of negative discharge and to secure the pump functioning over time.

FLOWRATE

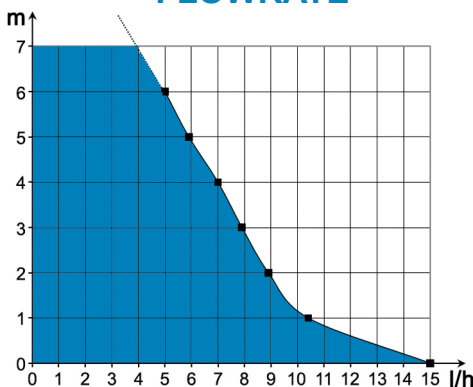

Kit pre-assembled

Pump is already installed in its duct. Installation is easy and quick.

CONTENTS



Duct with elbow- Finishing gasket - Finishing ceiling plate - Pump - Reservoir with air-vent tube - Power / alarm cable - Reservoir stand - Inlet tube - Suction tube 0.25m - Screws and rawlplugs

FLOWATCH® VISION

SICCOM

The only monoblock wall pump of the market, installed horizontally or vertically, for the condensate removal of air conditioners up to 10kW / 36000BTU.

Ref: DE05LCB900

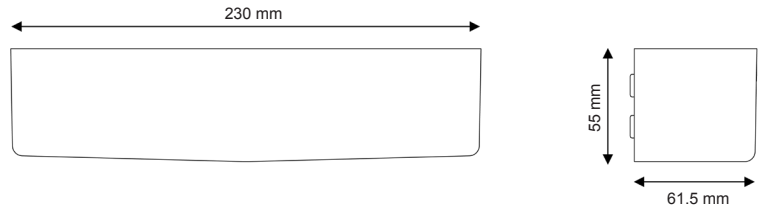

Hose diameter
Discharge : 6/9 mm - not supplied



BENEFITS

4 possible installations



World first - Can be installed horizontally or vertically, on the right or on the left of the air conditioner.

Easy maintenance

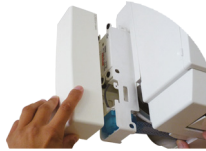

Access to the pump elements (reservoir, tubes etc.) is made by removing the cover.

Very silent



Very silent pump, suitable for an installation in any room.

Record size



Thanks to its small size, the FLOWATCH® VISION is the most discreet and aesthetic monoblock wall pump of the market.

SPECIFICATIONS

Flowrate max	15 l/h
Discharge head	10 m
Electrical power	19W
Voltage	220-240V 50/60Hz
Alarm	NO-NC
Noise level*	
Protection rating	IPX3
Thermal protection	Yes
Operating cycle**	100%
Power / alarm cable	1.4 m
Dimensions	230 x 61.5 x 55 mm

* Notation from 1 wave (≤ 20 dBA) to 6 waves (> 45 dBA)

** The pump is able to run 100% of the time if necessary.

FLOWRATE

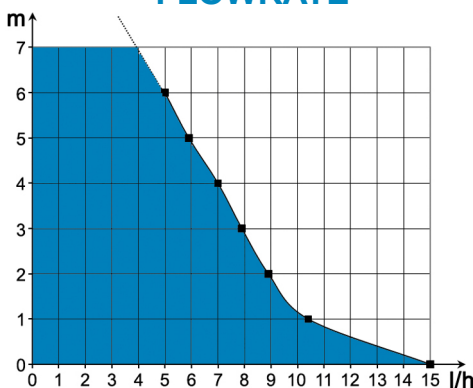

Reservoir with removing filter

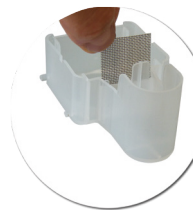

Prevents dust and particles to damage the pump. Easy to clean.

CONTENTS



Pump - Reservoir for horizontal installation - Reservoir for vertical installation - Inlet tube - Screws and rawplugs - 1 clamp

SUNNY FLOWWATCH® CLIM

SICCOM

Mini tank pump (solenoid) for the condensate removal of air conditioners
up to 10kW / 36000BTU.

Ref: DE05RCC060

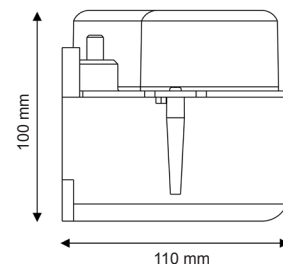
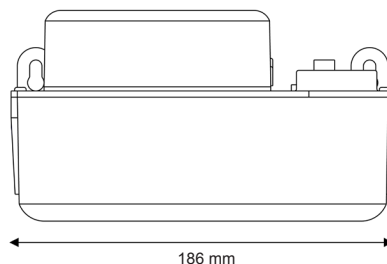

Hose diameter
Discharge : 6/9 mm - not supplied



SPECIFICATIONS

Flowrate max	15 l/h
Discharge head	10 m
Electrical power	19W
Voltage	220-240V 50/60Hz
Alarm	NO-NC
Noise level*	
Protection rating	IPX4
Thermal protection	Yes
Operating cycle**	100%
Power / alarm cable	1.5 m / 1.3 m
Dimensions	186 x 110 x 100 mm

* Notation from 1 wave (≤ 20 dBA) to 6 waves (> 45 dBA)
** The pump is able to run 100% of the time if necessary.

BENEFITS



Very silent

Very silent pump, suitable for an installation in any room.



Compact tank pump

The SUNNY FLOWWATCH® CLIM offers the best tank capacity/pump size of the market.



IPX4 protection

Protected against water splashes.



Removable integrated filter

Prevent dust and particles to damage the pump. Easy to remove and to clean.



Mounting brackets

Thanks to its mounting brackets (and screws and rawplugs supplied), pump can be easily fixed to the wall.



Inlet adapter included

This adapter allows condensate to enter the pump via tubes of different diameters.

FLOWRATE

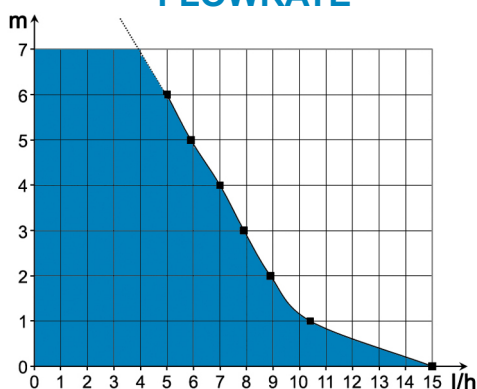

CONTENTS

Pump - Inlet tube - Screws and rawplugs

FLOWATCH® TANK

Centrifugal pump high efficiency for the removal of acid and charged condensates of gas condensing boilers.

Ref: DE13QCA700

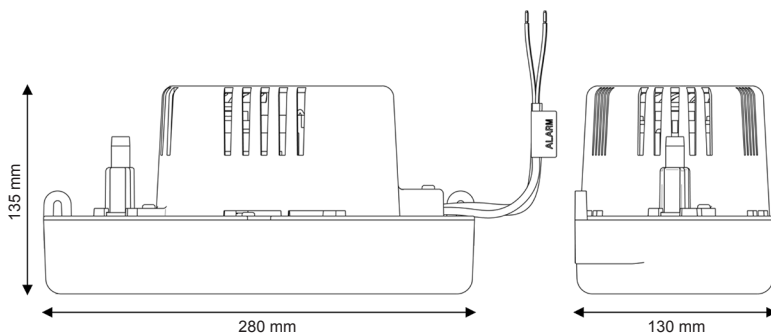

pH > 2.5

Hose diameter
Discharge : 9/12 ou 6/9 mm - not supplied



SPECIFICATIONS

Flowrate max	788 l/h
Discharge head	5.5 m
pH tolerated	pH > 2.5
Condensate max temperature	60°C
Electrical power	80W
Voltage	220-240V 50/60Hz
Alarm	NO-NC
Noise level*	
Protection rating	IP20
Thermal protection	Yes
Operating cycle**	30%
Power / alarm cable	2 m / 1 m
Dimensions	280 x 130 x 135 mm

* Notation from 1 wave (≤ 20 dBA) to 6 waves (> 45 dBA)
** The pump is able to run 30% of the time if necessary.

BENEFITS



High efficiency
Flowrate 788 l/h
Discharge head 5.5 m



Reversible pump
Allows the FLOWATCH® TANK to be installed in any configuration.



Removable check valve
The check valve supplied can be removed easily (1/4 turn) to be cleaned.



2 possible outlet diameters
Original outlet for 9/12mm tube
+ reducer for 6/9mm tube



Inlet adapter included
Avoids any problems in connecting the boiler to the pump.
(Can be purchased separately)

FLOWRATE

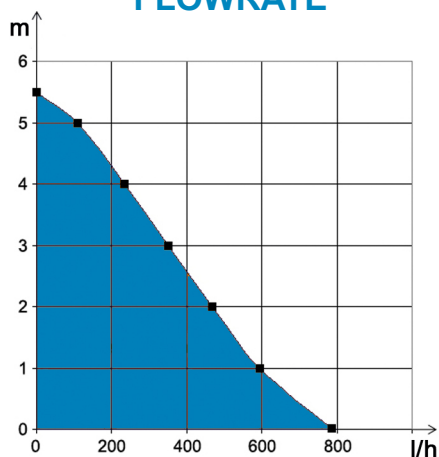

CONTENTS

Pump with check valve, 3 taps -
Inlet adaptor - 6/9mm outlet adaptor -
Screws and rawplugs

Centrifugal pump CP08

Universal centrifugal pump dedicated to split cassettes.

SICCOM

Ref: CP08SC6641

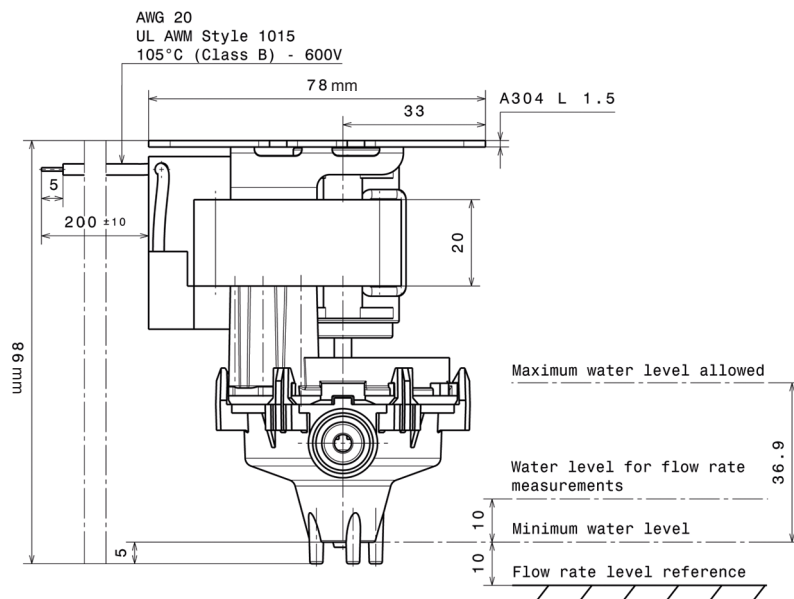
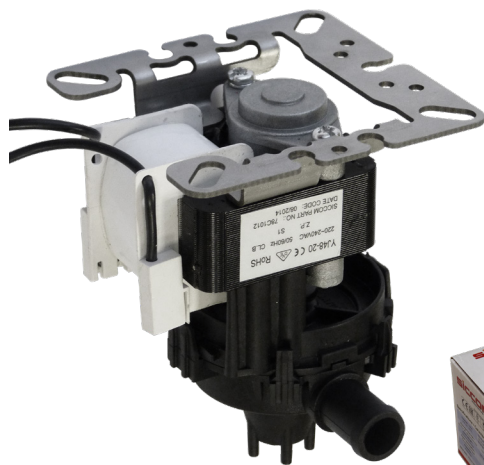

FLOWRATE

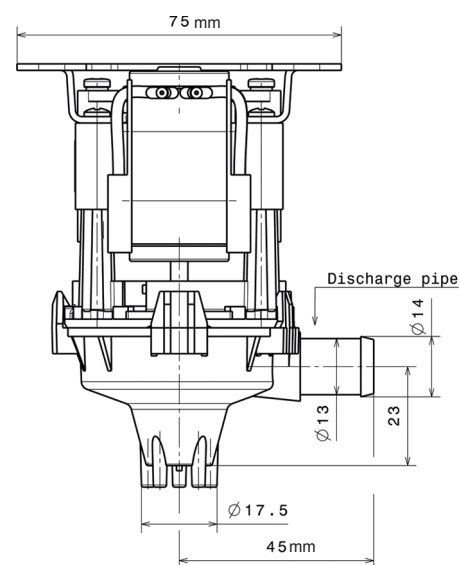
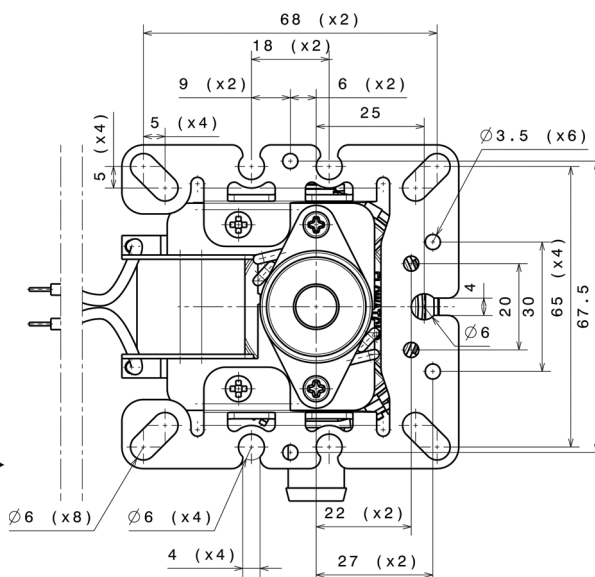
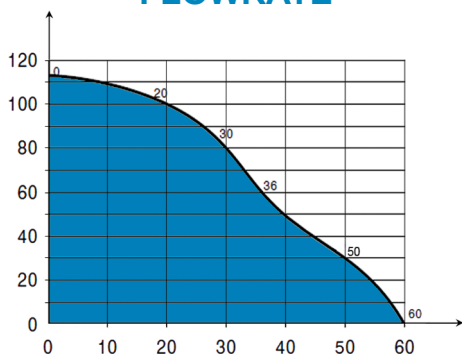

SPECIFICATIONS

Flowrate max	60 l/h
Discharge head	110 cm
Electrical power	8W
Voltage	220-240V 50/60Hz
Noise level*	
Protection rating	IP54
Temperature rise	66K
Operating cycle**	100%
Outlet tube	Ø 14 mm
Dimensions	82.5 x 76 x 97.3 mm

* Notation from 1 wave (≤ 20 dBA) to 6 waves (> 45 dBA)

** The pump is able to run 100% of the time if necessary.

BENEFIT

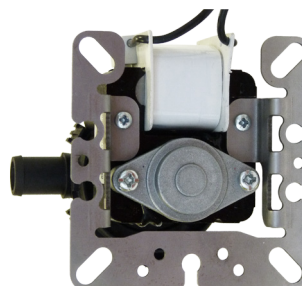

Universal plate

The CP08 mounting plate has been designed to fit the majority of cassette air conditioners on the market.

It can therefore easily replace another model of centrifugal pump at a cheaper price!

mini FLOWATCH® 0

SICCOM

Mini solenoid pump simple and economic for the condensate removal of air conditioners **up to 8kW / 27000BTU**.

Ref: DE05LCB980

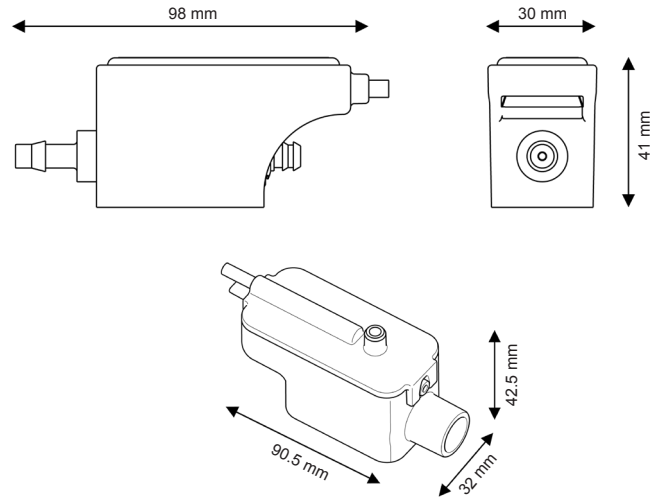

Hose diameter
Suction : 6/9 mm - not supplied
Discharge : 6/9 mm - not supplied

SPECIFICATIONS

Flowrate max	10 l/h
Suction head max	1.5 m
Discharge head	10 m
Electrical power	11W
Voltage	220-240V 50Hz only
Alarm*	No alarm
Noise level**	
Protection rating	IP20
Thermal protection	Yes
Operating cycle***	100%
Power cable	1.5 m
Dimensions	98 x 30 x 41 mm / 90 x 32 x 42 mm

* Alarm option available on request.

** Notation from 1 wave (≤ 20 dBA) to 6 waves (> 45 dBA)

*** The pump is able to run 100% of the time if necessary.

BENEFITS



Removable reservoir

Can be easily unclipped in order to clean the reservoir and the float.



Integrated filter

Plastic filter integrated to the reservoir. It prevents big impurities to damage the pump.



Accessories included

All necessary accessories are included in the box.



Compact pump

Very small, pump and reservoir are easy to install.

FLOWRATE

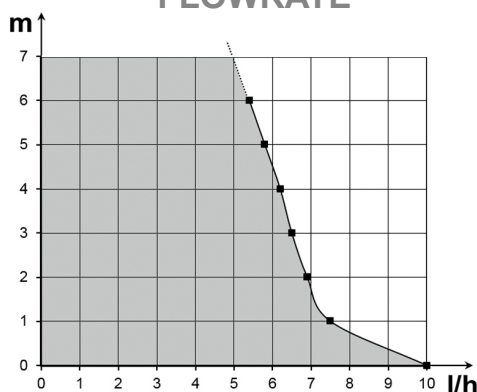

CONTENTS



Pump - Reservoir - Double-side adhesive for reservoir fixing - Inlet tube - 3 clamps

ECO FLOWATCH®

SICCOM

Mini solenoid pump simple and economic for the condensate removal of air conditioners up to 10kW / 36000BTU.

Ref: DE05LCC190

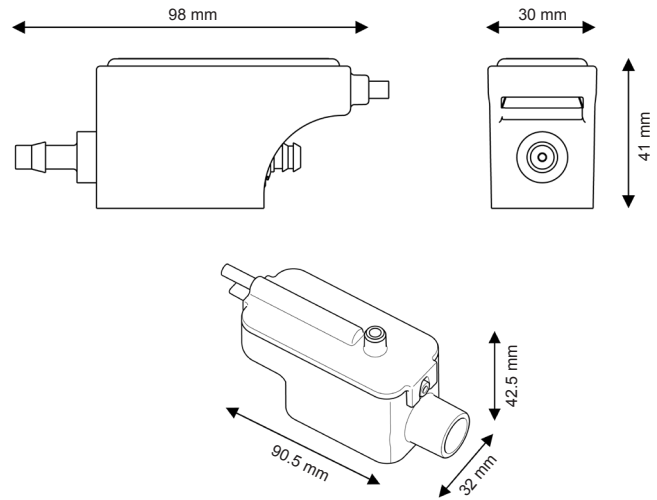
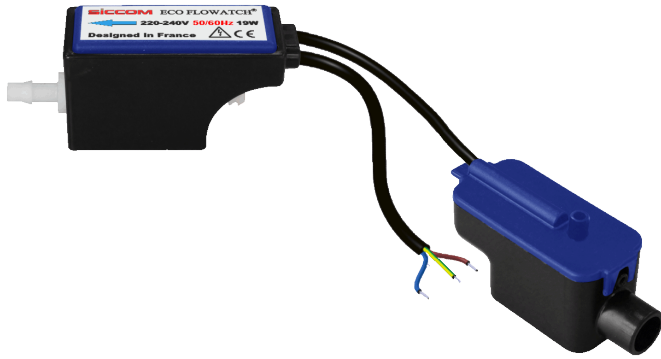

Hose diameter
Suction : 6/9 mm - not supplied
Discharge : 6/9 mm - not supplied

SPECIFICATIONS

Flowrate max	13.2 l/h
Suction head max	1.5 m
Discharge head	10 m
Electrical power	19W
Voltage	220-240V 50/60Hz
Alarm*	No alarm
Noise level**	
Protection rating	IP20
Thermal protection	Yes
Operating cycle***	100%
Power cable	1.5 m
Dimensions	98 x 30 x 41 mm / 90 x 32 x 42 mm

* Alarm option available on request.

** Notation from 1 wave (≤ 20 dBA) to 6 waves (> 45 dBA)

*** The pump is able to run 100% of the time if necessary.

BENEFITS



Removable reservoir

Can be easily unclipped in order to clean the reservoir and the float.



Integrated filter

Plastic filter integrated to the reservoir. It prevents big impurities to damage the pump.



Accessories included

All necessary accessories are included in the box.

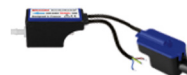

Compact pump

Very small, pump and reservoir are easy to install.

FLOWRATE

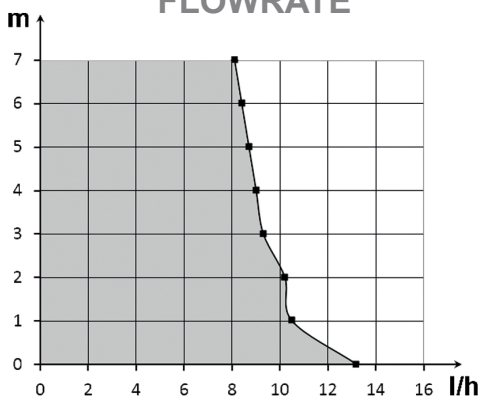

CONTENTS

Pump - Reservoir - Double-side adhesive for reservoir fixing - Inlet tube - 3 clamps



ECO FLOWATCH® DESIGN

SICCOM

Complete kit, in-duct pump, for the condensate removal of air conditioners up to 10kW / 36000BTU.

Ref: DE05LCD320

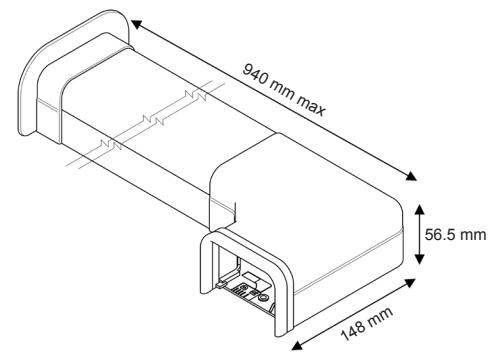
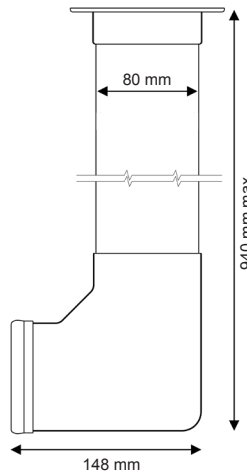
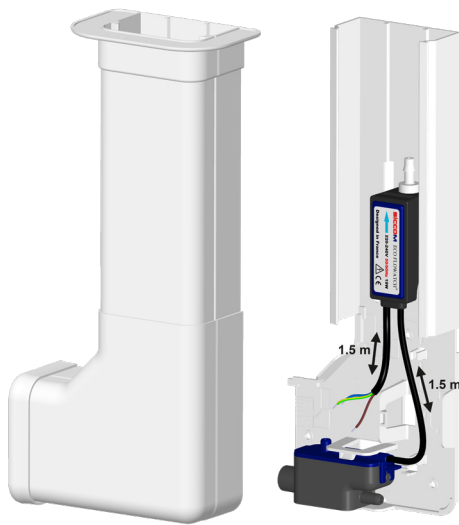

Hose diameter
Suction : 6/9 mm - not supplied
Discharge : 6/9 mm - not supplied



SPECIFICATIONS

Flowrate max	13.2 l/h
Suction head max	1.5 m
Discharge head	10 m
Electrical power	19W
Voltage	220-240V 50/60Hz
Alarm	No alarm
Noise level*	
Protection rating	IP20
Thermal protection	Yes
Operating cycle**	100%
Power cable	1.5 m
Trunking dimensions	80 x 55 x 800 m

* Notation from 1 wave (≤ 20 dBA) to 6 waves (> 45 dBA)

** The pump is able to run 100% of the time if necessary.

BENEFITS

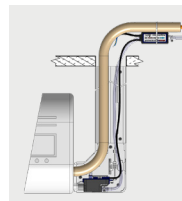

Possibility to move the pump away

Thanks to its 1.5 m cable, the pump unit can be moved away to reduce the noise level and facilitate installation.



Removable reservoir

Can be easily unclipped in order to clean the reservoir and the float.



Integrated filter

Plastic filter integrated to the reservoir. It prevents big impurities to damage the pump.



Accessories included

All necessary accessories are included in the box.

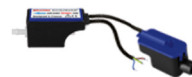

Compact pump

Very small, pump and reservoir are easy to install.



Nice design

Thanks to its shape and its finishing accessories (included), the ECO FLOWATCH® DESIGN offers great aesthetics qualities.

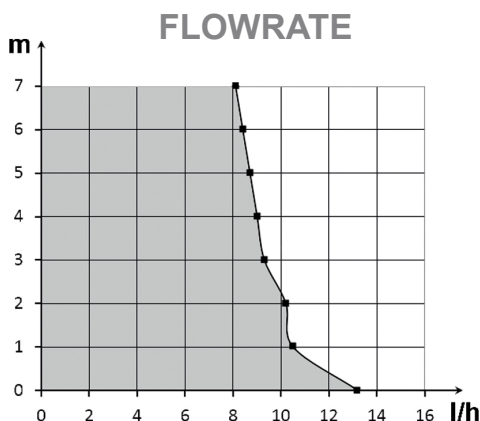

CONTENTS



Duct with elbow - Finishing gasket - Finishing ceiling plate - Pump ECO FLOWATCH - Reservoir - Inlet tube - Double-side adhesive - Clamps

ECO LINE

SICCOM

Mini in-line pump (solenoid), ultra compact and easy to install, for the condensate removal of air conditioners up to 10kW / 36000BTU.

Ref: DE05SCC600

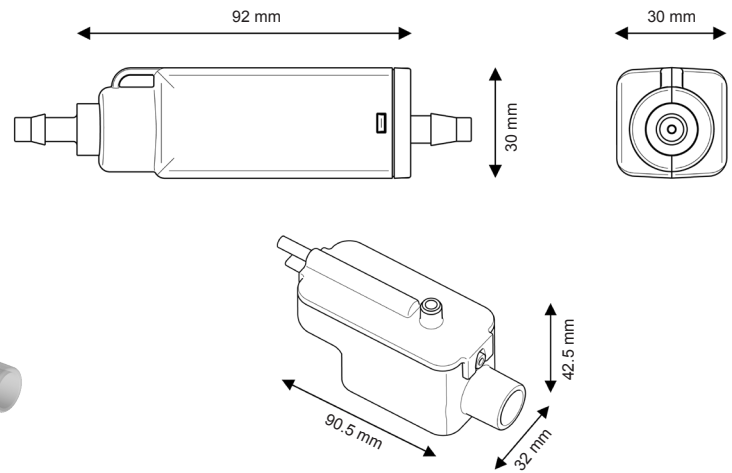
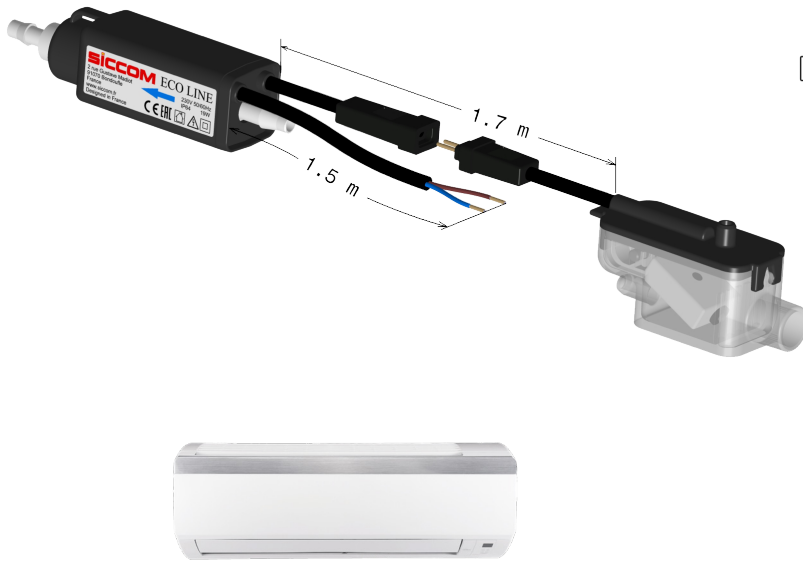

Hose diameter
Suction : 6/9 mm - not supplied
Discharge : 6/9 mm - not supplied

SPECIFICATIONS

Flowrate max	13.2 l/h
Suction head max	1.5 m
Discharge head	10 m
Electrical power	19W
Voltage	220-240V 50/60Hz
Alarm*	No alarm
Noise level**	
Protection rating	IP64
Thermal protection	Yes
Operating cycle***	100%
Power cable	1.5 m
Dimensions	92 x 30 x 30 mm / 90 x 32 x 42 mm

* Alarm option available on request.

** Notation from 1 wave (≤ 20 dBA) to 6 waves (> 45 dBA)

*** The pump is able to run 100% of the time if necessary.

FLOWRATE

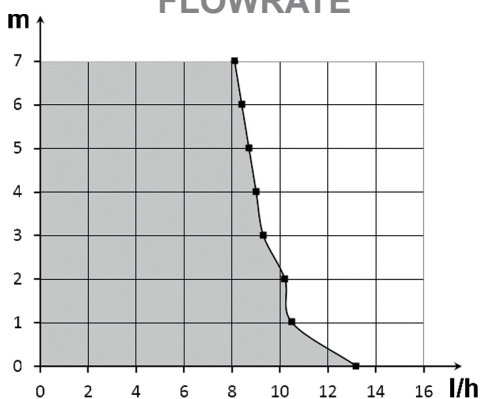

BENEFITS

ULTRA COMPACT pump

The most compact pump of the market!
Easy installation in a duct or inside the air conditioner.



IP64 protection

Protected against water splashes and dust.

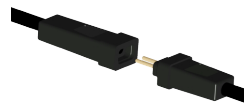

Quick connectors

Make installation and maintenance easier.

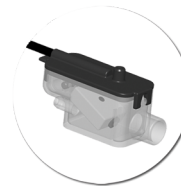

Removable clear reservoir

Allows a quick and easy viewing of the reservoir and the float. Easy to open and to clean.



Hanging bracket

This astucious hook allows to fix or hang the pump wherever you want (duct, false ceiling, inside de unit...).



Accessories included

All necessary accessories are included in the box.

CONTENTS

Pump - Reservoir - Double-side adhesive for reservoir fixing - Inlet tube - 3 clamps



MAXI ECO FLOWATCH®

SICCOM

Maxi solenoid pump, compact and powerful, for the condensate removal of air conditioners up to 30kW / 100 000BTU.

Ref: DE40LCC300

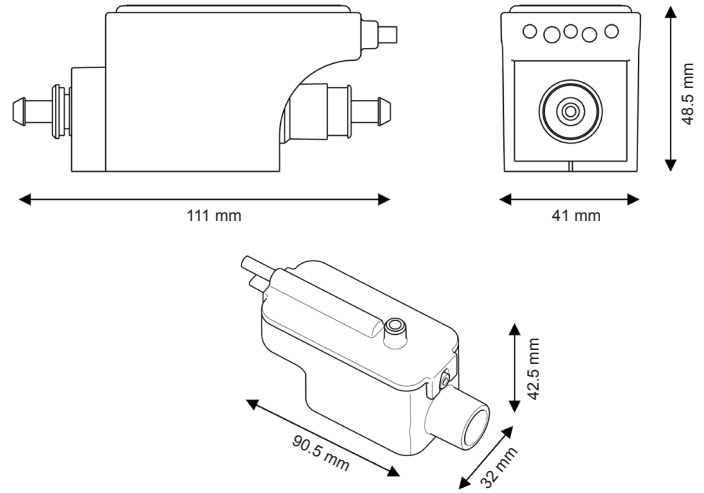
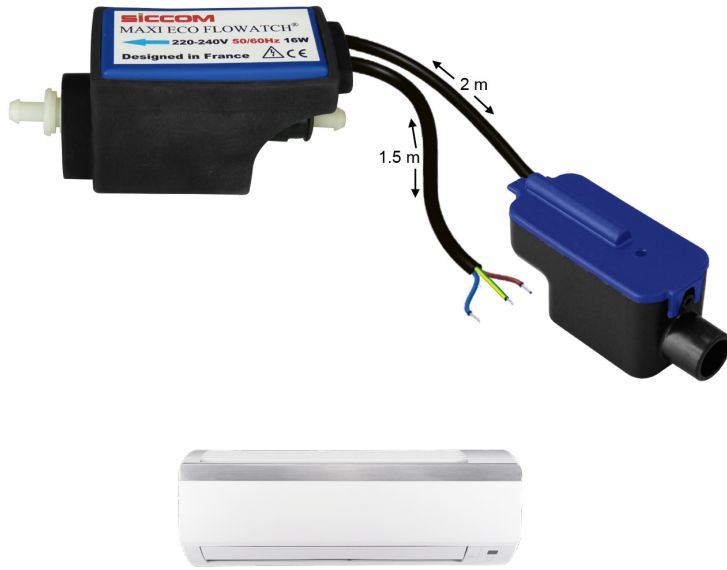

Hose diameter
Suction : 6/9 mm - not supplied
Discharge : 6/9 mm - not supplied

SPECIFICATIONS

Flowrate max	40 l/h
Suction head max	2 m
Discharge head	10 m
Electrical power	16W
Voltage	220-240V 50/60Hz
Alarm*	No alarm
Noise level**	
Protection rating	IP20
Thermal protection	Yes
Operating cycle***	100%
Power cable	1.5 m
Dimensions	111 x 41 x 48 mm / 90 x 32 x 42 mm

* Alarm option available on request.

** Notation from 1 wave (≤ 20 dBA) to 6 waves (> 45 dBA)

*** The pump is able to run 100% of the time if necessary.

FLOWRATE

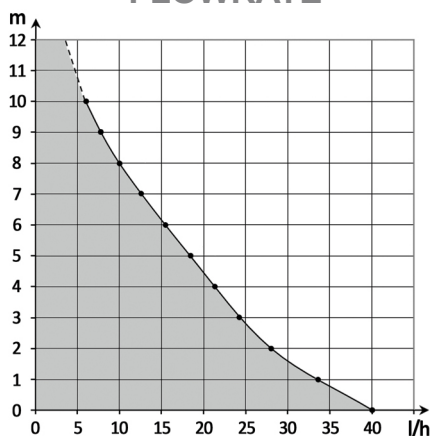

BENEFITS



Silent

The only pump of the world to offer such a flowrate with such a low noise.



High efficiency

Flowrate 40 l/h
Discharge head 10 m



Removable reservoir

Can be easily unclipped in order to clean the reservoir and the float.



Integrated filter

Plastic filter integrated to the reservoir. It prevents big impurities to damage the pump.



Accessories included

All necessary accessories are included in the box.



Compact pump

Very small, pump and reservoir are easy to install.



CONTENTS

Pump - Reservoir - Double-side adhesive for reservoir fixing - Inlet tube - 3 clamps

mini FLOWATCH® 1 EVO

SICCOM

Economical mini solenoid pump, with alarm, for the condensate removal of air conditioners up to 10kW / 36000BTU.

Ref: DE05LCD600



NEW

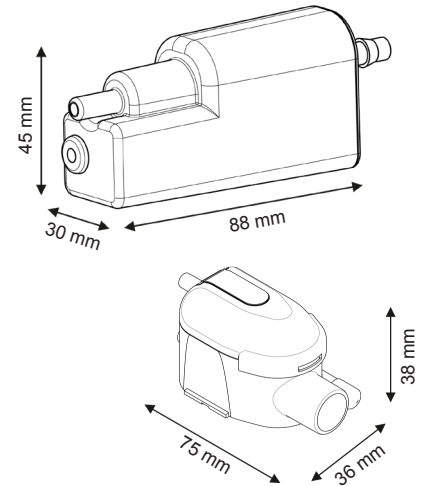

Hose diameter
Suction : 4/6 mm - supplied
Discharge : 6/9 mm - not supplied

SPECIFICATIONS

Flowrate max	13.2 l/h
Suction head max	1.5 m
Discharge head	10 m
Electrical power	19W
Voltage	220-240V 50/60Hz
Alarm	NC
Noise level*	
Protection rating	IP24
Thermal protection	Yes
Operating cycle**	100%
Power / alarm cable	1.5 m
Dimensions	88 x 30 x 45 / 75 x 36 x 38 mm

* Notation from 1 wave (≤ 20 dBA) to 6 waves (> 45 dBA)

** The pump is able to run 100% of the time if necessary.

BENEFITS



Quick connectors

Make installation and maintenance easier.



Clear reservoir

Facilitates maintenance thanks to a quick visualization of the reservoir state.



Removable integrated filter

The reservoir has a metal filter that can be easily removed for quick cleaning.



Alarm function

The NC alarm on the mini FLOWATCH® 1 EVO allows to cut off the air conditioner power supply in the event of condensate overflow.



IP24 protection

Protected against water splashes.



Accessories included

Necessary accessories are supplied in the box.

FLOWRATE

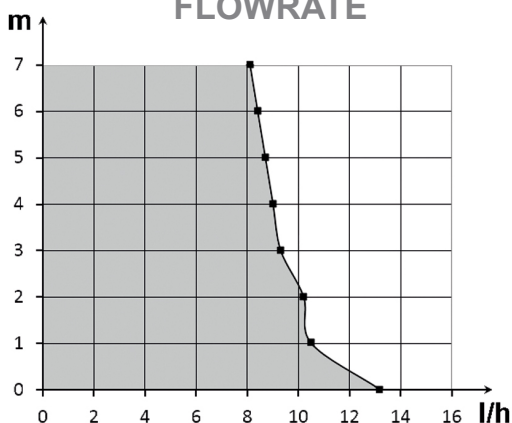

CONTENTS

Pump - Reservoir with air-vent tube
- Double-side adhesive - Inlet tube -
Suction tube 1.5m - 3 clamps

FLOWITA EVO

Wall-mounted monobloc pump, dismantlable, for the condensate removal from air conditioners up to 10kW / 36000BTU.

Ref: DE05LCC440



NEW

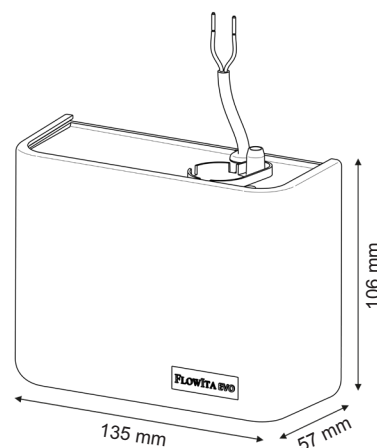
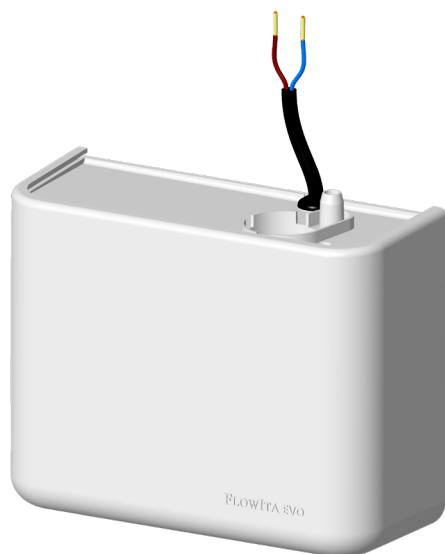

Hose diameter
Discharge : 6/9 mm - not supplied



SPECIFICATIONS

Flowrate max	13.2 l/h
Discharge head	10 m
Electrical power	19W
Voltage	220-240V 50/60Hz
Alarm*	Optional
Noise level**	
Protection rating	IP24
Thermal protection	Yes
Operating cycle***	100%
Power cable	0.8 m
Tank capacity	170 ml
Dimensions	135 x 57 x 106.5 mm

* Alarm option available on request.

** Notation from 1 wave (≤ 20 dBA) to 6 waves (> 45 dBA)

*** The pump is able to run 100% of the time if necessary.

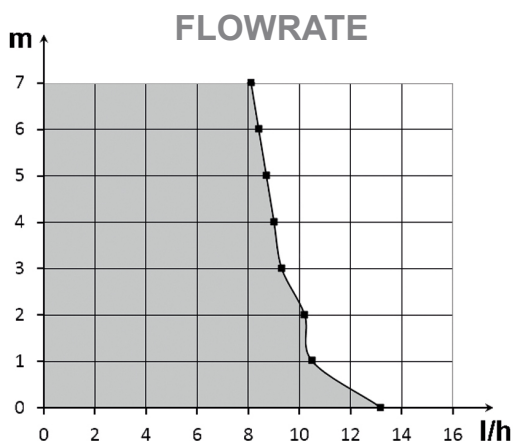

BENEFITS

Dismountable

The FLOWITA EVO can be disassembled in seconds!

Front panel, tank, suction tube... all the elements are removable.

Installation and maintenance has never been so quick and easy!

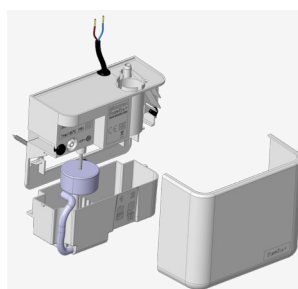

100ml pumping cycles

Its large reservoir allows the pump to operate optimally: larger and less frequent pumping cycles.



Extremely silent

The most discreet wall-mounted pump on the market!



Quick installation

The FLOWITA EVO can be installed easily and quickly underneath any air conditioner.



IP24 protection

Protected against water splashes.

CONTENTS

Pump - Screws and rawplugs



ECOTANK+ 1.2 / 2.5

SICCOM

Centrifugal tank pump for the removal of condensates from air conditioners, refrigerated displays or gas condensing boilers.

Ref ECOTANK+ 1.2 50Hz: DE12QCC610
 Ref ECOTANK+ 2.5 50Hz: DE25QCC620
 Ref ECOTANK+ 2.5 60Hz: DE25QCD140



pH > 2.5



SPECIFICATIONS

	50Hz version	60Hz version
Flowrate max	300 l/h	400 l/h
Discharge head	4.6 m	6 m
pH tolerated	pH > 2.5	pH > 2.5
Condensates max temp.	40°C	40°C
Electrical power	65W	65W
Voltage	230V 50Hz	230V 60Hz
Alarm	NO-NC	NO-NC
Noise level		
Protection rating	IP24	IP24
Thermal protection	Yes	Yes
Operating cycle*	30%	30%
Cable length	1.5 m	1.5 m
Dimensions ECOTANK+ 1.2	280 x 130 x 129 mm	
Dimensions ECOTANK+ 2.5	280 x 130 x 159 mm	

* Notation from 1 wave (≤ 20 dBA) to 6 waves (> 45 dBA)

** The pump is able to run 30% of the time if necessary.

FLOWRATE

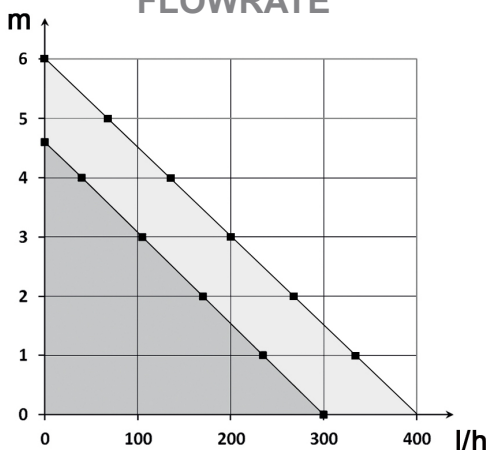

BENEFITS



IP24 protection

The pump is protected against water splashes.



Universal electric plug

Power/alarm cable can be taken off, making easy installation and maintenance.

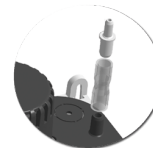

Outlet for 6/9 or 9/12 mm tube

Thanks to its connector supplied, the discharge can be made with a 6/9mm or a 9/12mm tube.



High capacity tank

Thanks to its 2.5 l tank, the ECOTANK+ 2.5 reduces the number of pumping cycles and answers to a great deal of applications.



Compact tank pump

With only 129mm height, the ECOTANK+ 1.2 fits easily in any space.



Reversible tank

Turning the tank allows to fit in any configuration.



PVC clear tube included (only in 60Hz version)

A 6m discharge tube (10x13mm diameter) is included in the ECOTANK+ 2.5 60Hz version.



CONTENTS

Pump - Cable power / alarm - 6/9mm outlet adaptor - Screws and rawplugs - PVC clear tube 6m (only in 60Hz version)

mini FLOWATCH® 2 DUO

SICCOM

Mini solenoid pump reliable and silent for the condensate removal of gas condensing boilers up to 60kW / 200 000BTU.

Ref: DE05LCC500

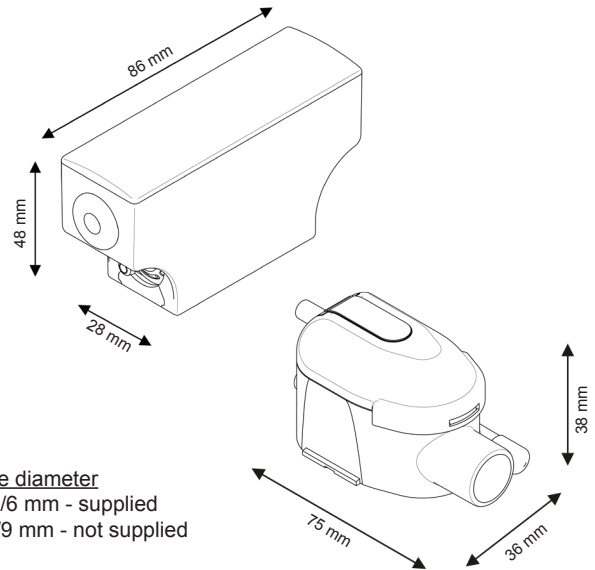

Hose diameter
Suction : 4/6 mm - supplied
Discharge : 6/9 mm - not supplied

pH > 2.5



SPECIFICATIONS

Flowrate max	19 l/h
Suction head max	0,5 m
Discharge head	10 m
pH tolerated	pH > 2.5
Electrical power	19W
Voltage	220-240V 50/60Hz
Alarm	NO-NC
Noise level*	
Protection rating	IP64
Thermal protection	Yes
Operating cycle**	100%
Power / alarm cable	1.6 m
Dimensions	86 x 28 x 48 mm / 75 x 38 x 36 mm

* Notation from 1 wave (≤ 20 dBA) to 6 waves (> 45 dBA)

** The pump is able to run 100% of the time if necessary.

FLOWRATE

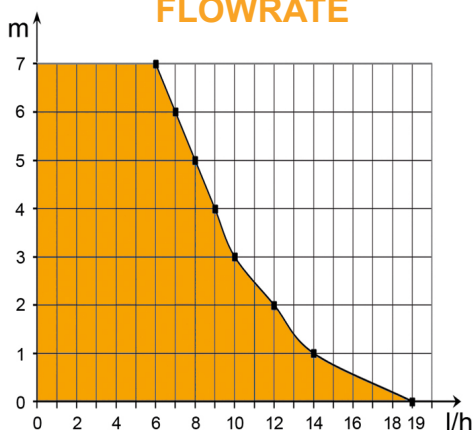

BENEFITS



Very silent

Very silent pump, suitable for an installation in any room.



Quick connectors

Make installation and maintenance easier.



Treated brass outlet

This brass outlet is specially treated to support acid condensates, and is more solid and reliable than plastic outlet.



IP64 protection

Protected against water splashes and dust.



Clear reservoir

Facilitates maintenance thanks to a quick visualization of the reservoir state.

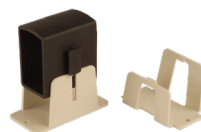

Kit Silence supplied

Pump stand and reservoir stand make the installation easier and reduce the noise level.



CONTENTS

Pump - Reservoir with air-vent tube - Power / alarm cable - Pump stand - Reservoir stand - Double-side adhesive - Inlet tube - Suction tube 0.25m - 1 clamp

FLOWATCH® VISION DUO

SICCOM

Monoblock wall pump (solenoid), silent and innovative, for the condensate removal of gas condensing boilers up to 60kW / 200 000BTU.

Ref: DE05LCC510

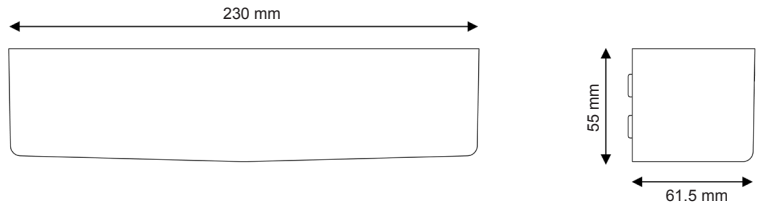

Hose diameter
Discharge : 6/9 mm - not supplied

pH > 2.5



BENEFITS



4 possible installations

World first - Can be installed horizontally or vertically, on the right or on the left of the boiler.



Very silent

Very silent pump, suitable for an installation in any room.

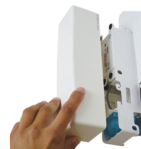

Very easy maintenance

Access to the pump elements (reservoir, tubes etc.) is made by removing the cover.



Record size

Thanks to its small size, the FLOWATCH® VISION DUO is the most discreet and aesthetic monoblock wall pump of the market.

SPECIFICATIONS

Flowrate max	19 l/h
Discharge head	10 m
pH tolerated	pH > 2.5
Electrical power	19W
Voltage	220-240V 50/60Hz
Alarm	NO-NC
Noise level*	
Protection rating	IPX3
Thermal protection	Yes
Operating cycle**	100%
Power / alarm cable	1.4 m
Dimensions	230 x 61.5 x 55 mm

* Notation from 1 wave (≤ 20 dBA) to 6 waves (> 45 dBA)

** The pump is able to run 100% of the time if necessary.

FLOWRATE

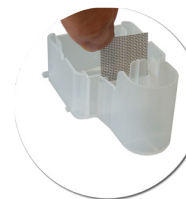
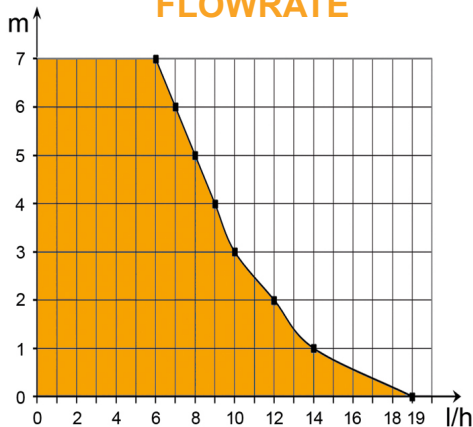

Reservoir with removable filter

Prevent dust and particles to damage the pump. Easy to clean.



CONTENTS

Pump - Inlet tube - Screws and rawplugs
- 1 clamp

SUNNY FLOWWATCH® DUO

SICCOM

Mini tank pump (solenoid) for the condensate removal of gas condensing boilers up to 60kW / 200 000BTU.

Ref: DE05NCC090

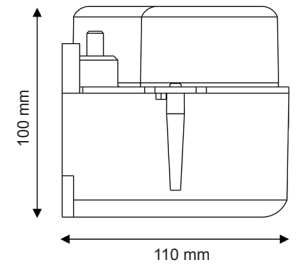
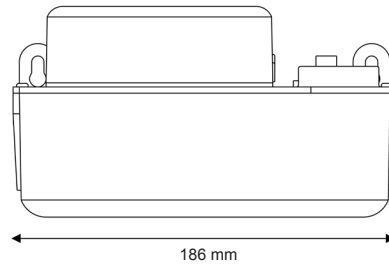

Hose diameter
Discharge : 6/9 mm - not supplied

pH > 2.5



SPECIFICATIONS

Flowrate max	19 l/h
Discharge head	10 m
pH tolerated	pH > 2.5
Electrical power	19W
Voltage	220-240V 50/60Hz
Alarm	NO-NC
Noise level*	
Protection rating	IPX4
Thermal protection	Yes
Operating cycle**	100%
Power / alarm cable	1.5 / 1.3 m
Dimensions	186 x 110 x 100 mm

* Notation from 1 wave (≤ 20 dBA) to 6 waves (> 45 dBA)
** The pump is able to run 100% of the time if necessary.

BENEFITS



Very silent

Very silent pump, suitable for an installation in any room.



Compact tank pump

The SUNNY FLOWWATCH® DUO offers the best tank capacity/pump size of the market.



IPX4 protection

Protected against water splashes.



Removable integrated filter

Prevent dust and particles to damage the pump. Easy to remove and to clean.



Mounting brackets

Thanks to its mounting brackets (and screws and rawplugs supplied), pump can be easily fixed to the wall.



Inlet adapter included

This adapter allows condensate to enter the pump via tubes of different diameters.

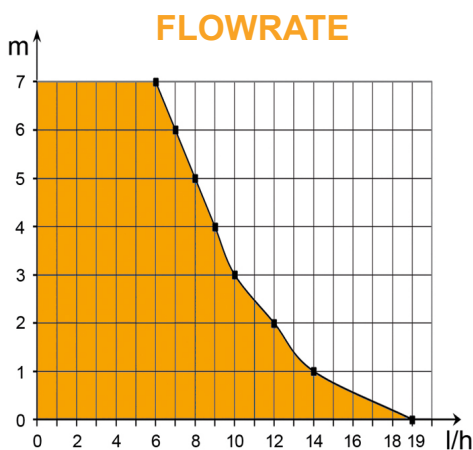

CONTENTS

Pump - Inlet tube - Screws and rawplugs

Pump accessories

Discover the range of accessories for SICCOM pumps, allowing easy installation and maintenance.



Connection extension kit
(extension cable 2m + suction tube 2m)
Ref: GC1KCTC710

This kit, coupled with a FLOWATCH® DESIGN, allows to move the pump in a false ceiling, and so:

- **REDUCE THE NOISE LEVEL**
- **FREED UP SPACE IN THE DUCT**

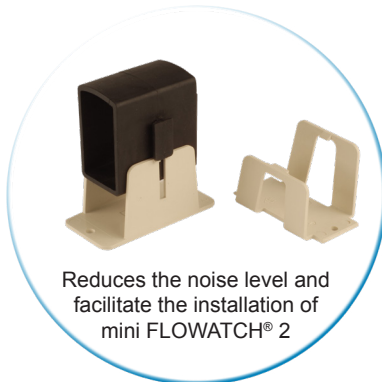
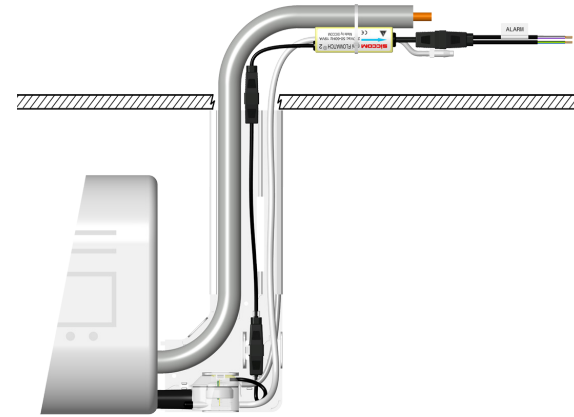

Reduces the noise level and facilitate the installation of mini FLOWATCH® 2

Kit Silence
Ref: GC1KFX2010



The Stop Siphoning prevents the phenomenon of negative discharge on any installation.

Stop Siphoning
Ref: GC092A1001 (sachet de 10)
GC092A1002 (1 pièce)



Replacement reservoir for FLOWATCH® DESIGN

Short cable reservoir + air vent tube
Ref: GCDS3BTF4180



Replacement reservoir for mini FLOWATCH® 2

Long cable reservoir + air vent tube
Ref: GCDS3BTF4650

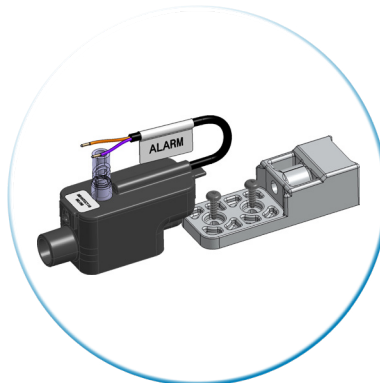

Alarm kit ECO pumps
Ref: DS1HTCC110

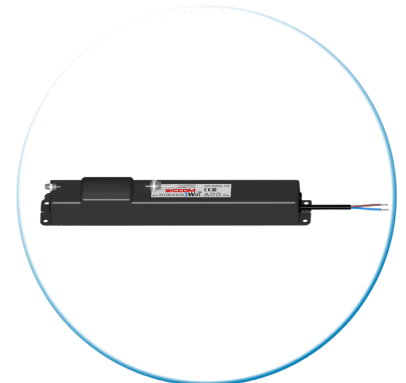

Relay mini FLOWATCH® 3 WiFi
Ref: DE05WFCR760



Bending tube Øint. 15mm
Ref: GC025D1017



Inlet adapter
FLOWATCH® TANK
Ref: GC078H2008



Inlet adapter
SUNNY FLOWATCH®
Ref: GC078H2007



Check valve
FLOWATCH® TANK
Ref: 91A1006

Sensors

SICCOM also manufactures level and proximity sensors. Discover a part of our range below, and do not hesitate to contact us for further information.

Vertical sensors



DG series
Standard



DP series
Compact



DK series



DX series
Stainless steel



DY series
Detection by microswitches

Horizontal sensors



DHN series
Threaded fixing



DHG series
Seal compression fixing



DHM series
Nut fixing



DXN series
Stainless steel

Specific sensors

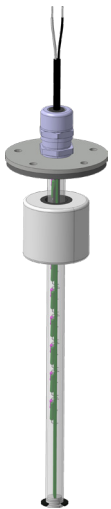

DC series
Multi-level resistive rod

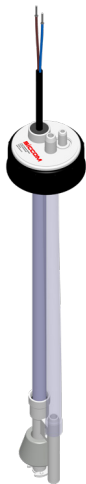

DB series
Suction cane with level detector



DD series
Resistive probe



DP series
Proximity sensors



OEM series
On-demand products



Find more informations on our website

Sensors for all your applications



and the medical, food, hydrocarbon, transportation, automotive industries...

Condensate removal pumps

SICCOM is established all across the world.
As an international manufacturer, we are committed to product quality and reliability.

Listening, communication and service are the three key values for our customer approach.

We will be delighted to provide further information, so please
CONTACT US.



France

Tel: +33 6 83 82 46 02
Email: ychaves@siccom.fr

Italy, Switzerland & Central Europe

Tel/Fax: +39 02 96 36 21 40
Email: cconsales@siccom.fr

Spain & Latin America

Tel: +34 622 487 110
Email: tducasse@siccom.fr

Western Europe

Tel: +33 6 42 05 33 22
Email: pparadis@siccom.fr

SICCOM France - Headquarter International customer service

2, rue Gustave Madiot
ZI Les Bordes
91070 Bondoufle
Tel: +33 1 60 86 81 48
Email: commercial@siccom.fr

Northern & Eastern Europe

Tel: +33 6 83 82 46 00
Email: pgvassort@siccom.fr

Africa & Middle East

Tel: +33 6 42 05 33 22
Email: pparadis@siccom.fr

Northern America

Tel: +33 6 42 05 33 22
Email: pparadis@siccom.fr

India

Tel: +91 99 9900 3240
Email: djagga@siccom.fr

Asia

Tel: +33 6 43 31 19 27
Email: jlrendu@siccom.fr

Oceania

Tel: +33 6 83 82 46 00
Email: pgvassort@siccom.fr